

UltraCleaner

Robotic Torch Cleaner



The IWE UltraCleaner is the first non-mechanical cleaner that can automatically remove spatter from any robotic GMAW torch including twin wire. The ultrasonic waves created in the anti-spatter fluid remove spatter from all torch components; including the contact tip, diffuser and nozzle. Longer consumable life is obtained because the UltraCleaner **cools as it cleans**.

The ultrasonic cleaning process has many other advantages over conventional cleaning methods:

- Cools, Cleans and Coats for extended consumable life
- Simple installation and programming
- Cleans all types and sizes of nozzles
- Limit Switch or Robot I/O activated
- Non-contact, no damage to consumables
- No moving parts to replace
- Automatic fluid dispensing maintains fill level

Specifications

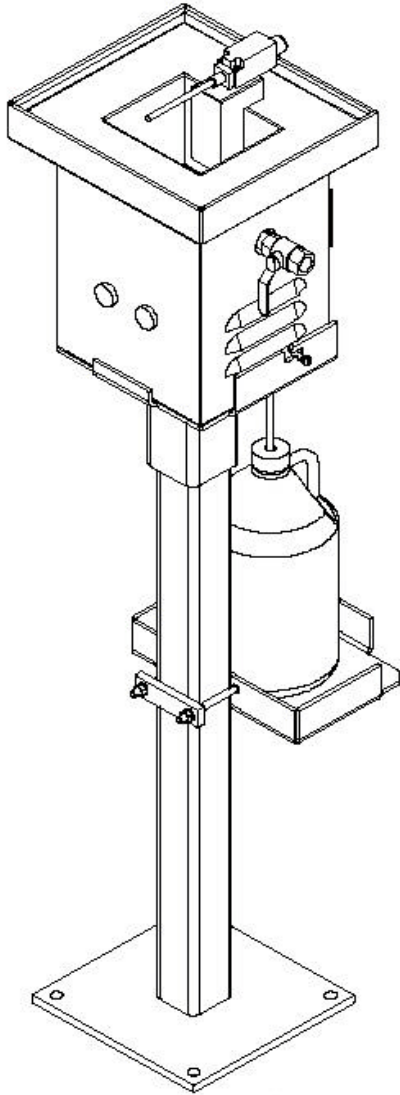

UltraCleaner

Dimensions

Height	15" (38 cm)
Width	9" (22.8 cm)
Length	10" (25.4 cm)
Weight	18.5 lb (8.4 kg)

Power

Input Voltage	120VAC
Input Amperage	3 Amps
Frequency	50/60HZ
Fuse size	5 Amps
Transducer power	300 Watts Peak
Power Cord Length	25 ft (7.5m)

Tank Dimensions

Volume	½ gal. (1.89 L)
Depth	5" (12.7 cm)
Width	5" (12.7 cm)
Length	6" (15.2 cm)

Material

Tank	16 gauge 316L Stainless Steel
Enclosure	20 gauge 316L Stainless Steel

Specifications subject to change without notice

Shown with optional stand and Anti-Splatter shelf

Description	Stock No.
Model 1: UltraCleaner, Limit Switch Activated	A021105
Model 2: UltraCleaner, I/O Controlled w/ 25 ft. Cable	A031202
Model 3: UltraCleaner, Dual Robot I/O Controlled w/ 25 ft. Cable	A031220
Accessories	
Torch Air Blast Control	A031170
Stand, Adjustable w/Anti-Splatter Fluid Shelf	A031162F
Stand, Adjustable	A041206F
Stand, Fixed Height (XX=height/inches)	A031203-XX
Location Plate (Used to locate UltraCleaner when stand is not used)	A041210F
Magnet Cleaner	A041211M
Fluid Cleaner (dash 1 = 1 gallon, dash 5 = 5 gallon)	A041212-1
	A041212-5



Manufactured by:
IWE - International Wire Exchange
Sales, Applications and Technical Spec's:
Phone: (248) 519-5068 - FAX (248) 232-7868
E-Mail: sales@iwexchange.com
Web: www.iwexchange.com/ultracleaner